

**Theia**<sup>®</sup>  
TECHNOLOGIES

**SL940 / TL936 Family  
Telephoto Varifocal Lens  
9–40mm - Day/Night**

- ◆ **Telephoto Varifocal 9 – 40mm** (SL940), 9-36mm (TL936)
- ◆ IR corrected for **Day/Night** cameras
- ◆ **5 megapixel resolution** for demanding applications Short
- ◆ length, **<50mm** from CS mount
- ◆ Supports **1/3” to 1/2.5”** sensor **Day/Night** cameras

Lenses	<b>SL940A</b> DC-autoiris	<b>SL940M</b> Manual iris
Focal length	9-40mm	
Resolution	Up to 5MPix resolution	
F/#	F/1.5 to close	
IR Correction	Day/Night	
Mount	CS	
Lens length	49.3mm from mount	
Minimum focal distance	2.5m	
Iris cable length	10cm	N/A
Weight	65g	
Operating Temp	-20C to 60C	
Storage Temp	-20C to 70C	

Sensor size	<b>1/3”</b>	<b>1/2.7” HD</b>	<b>1/2.5”</b>
Field of view (H)	30° - 7.1°	37° - 8.6°	36° - 8.5°
Field of view (V)	22° - 5.3°	20° - 4.8°	27° - 6.3°
Field of view (D)	38° - 8.8°	42° - 9.9°	46° - 10.6°

SL940A prototype preliminary

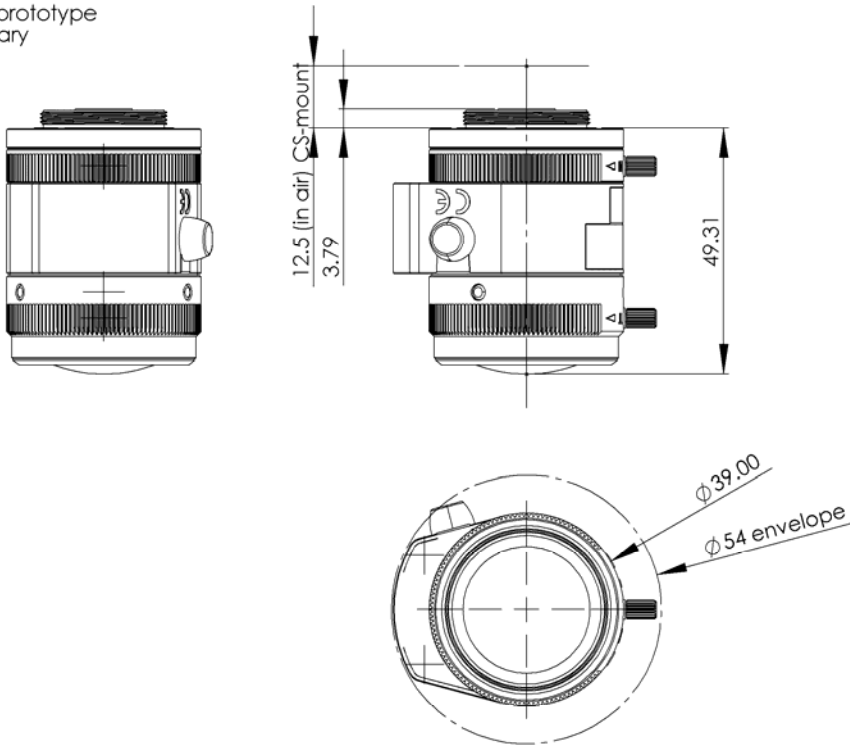

**PROPRIETARY AND CONFIDENTIAL**  
THE INFORMATION CONTAINED IN THIS DRAWING IS THE SOLE PROPERTY OF THEIA TECHNOLOGIES. ANY REPRODUCTION IN PART OR AS A WHOLE WITHOUT THE WRITTEN PERMISSION OF THEIA TECHNOLOGIES IS PROHIBITED.

Optimal glass insertion is 2mm between lens and sensor.  
Back focus is 12.5mm in air.

### Autoiris lens

The iris operation is controlled electronically by the camera with DC autoiris control. The autoiris cable should be connected to the camera's iris cable receptacle. Refer to your camera manufacturer's operators manual to set the camera's iris control to "DC autoiris".

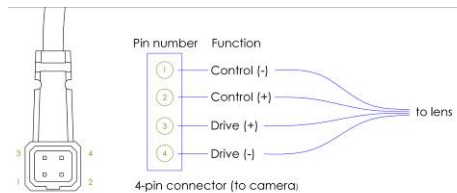

Drive Voltage range: 3V (+1/-0.5 V)  
Max current consumption: 22mA (max V/Drive  $\Omega$ )  
Drive coil resistance: 190 $\Omega$   
Damper coil resistance: 855 $\Omega$

## Visible MTF

## IR 850nm MTF

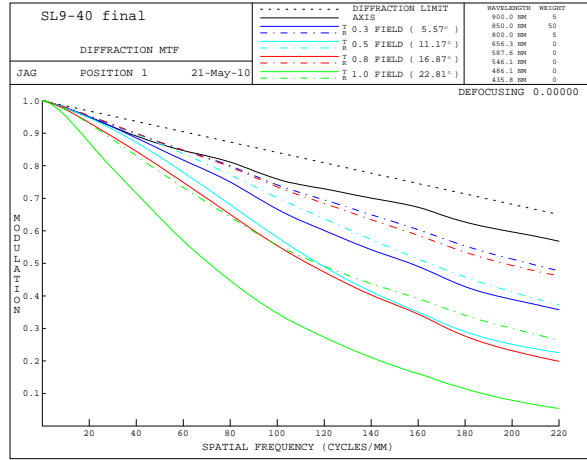
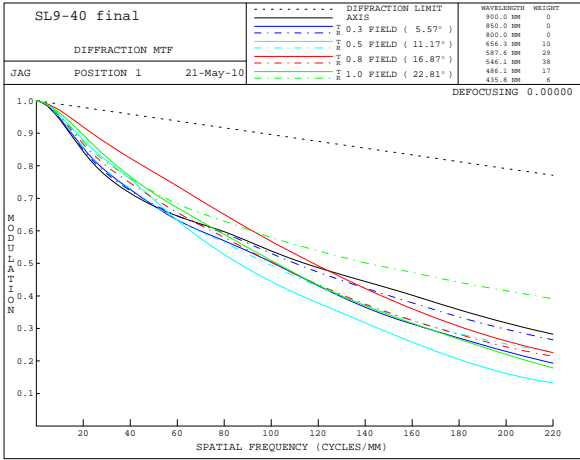

Wide Position

Wide Position

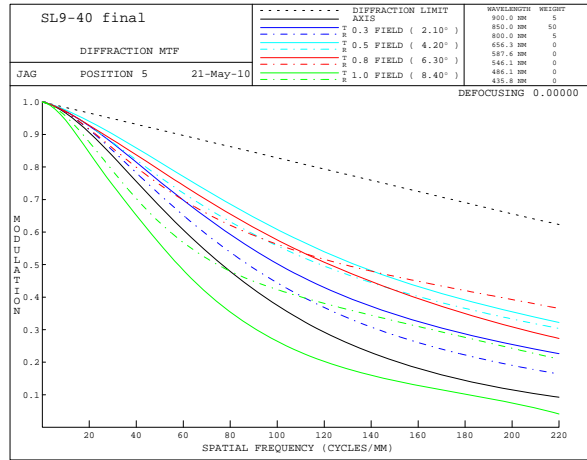
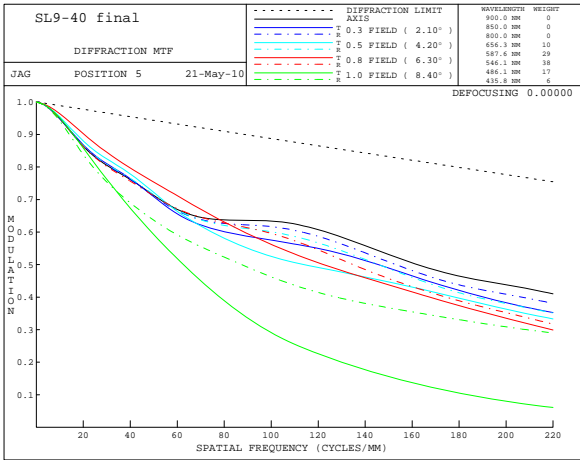

Mid Position

Mid Position

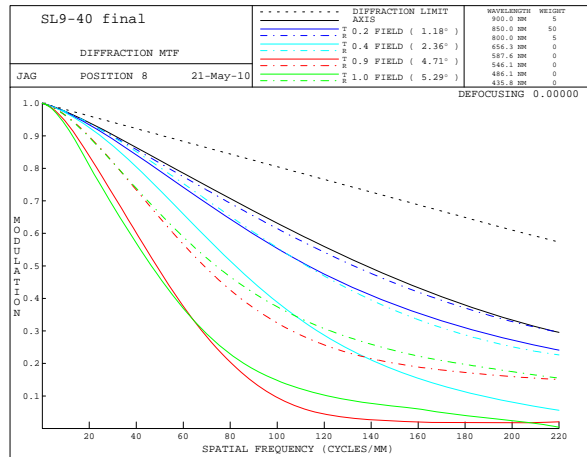
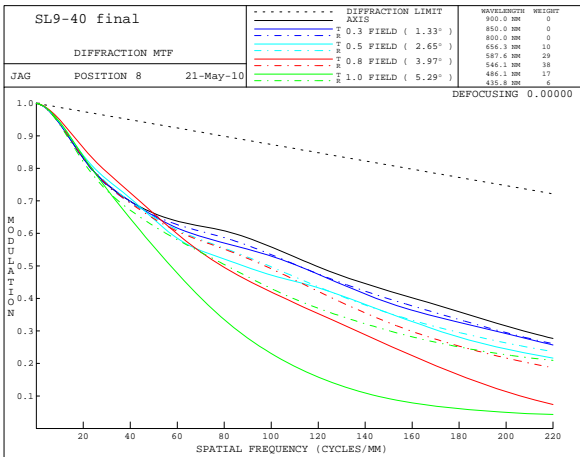

Narrow Position

Narrow Position

## Temperature Performance

Theia Technologies Confidential

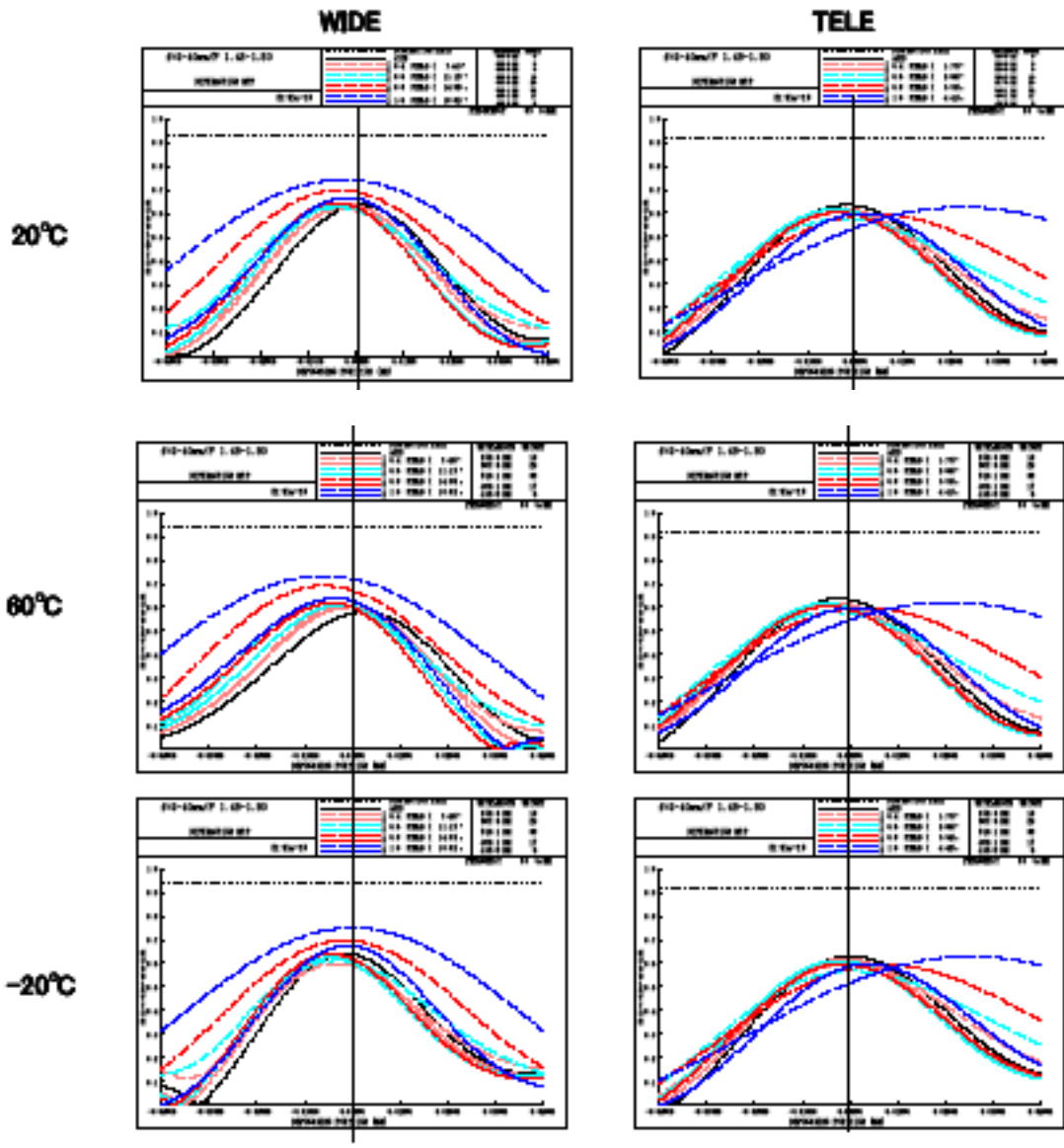

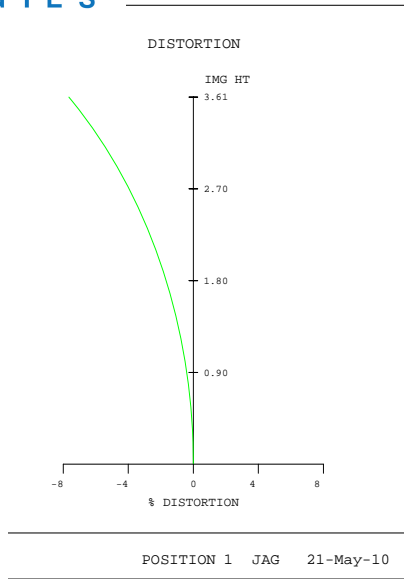

Wide Position

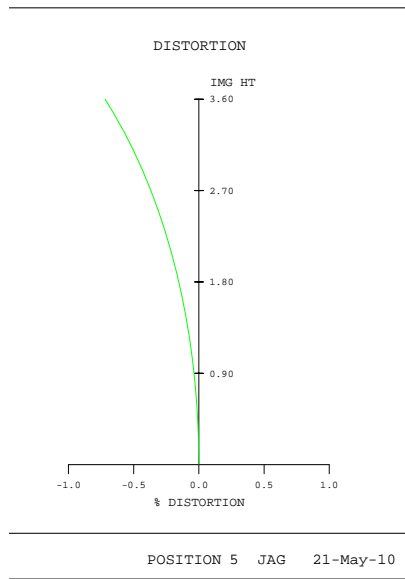

Mid Position

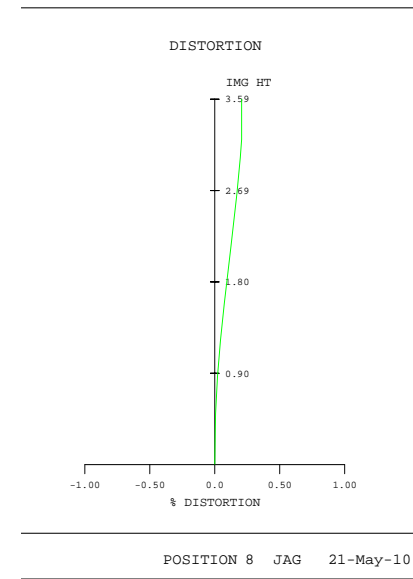

Narrow Position

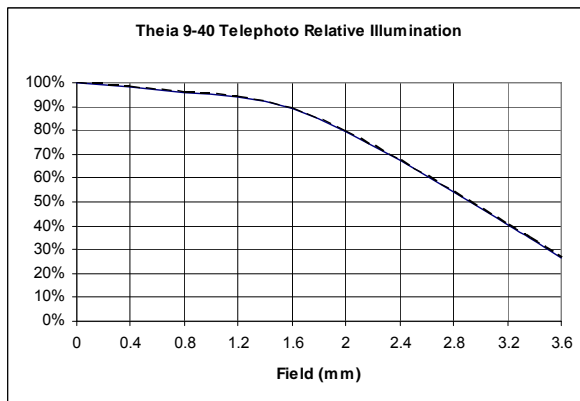

Wide Position

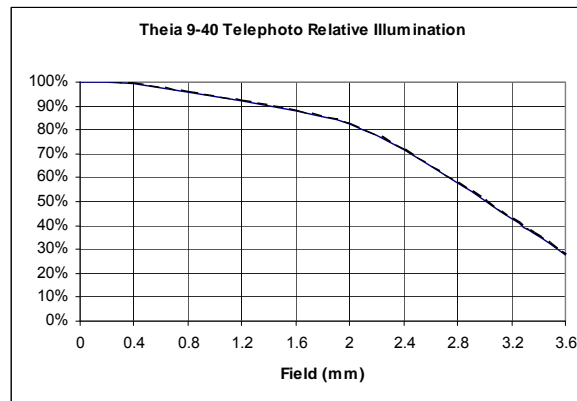

Mid Position

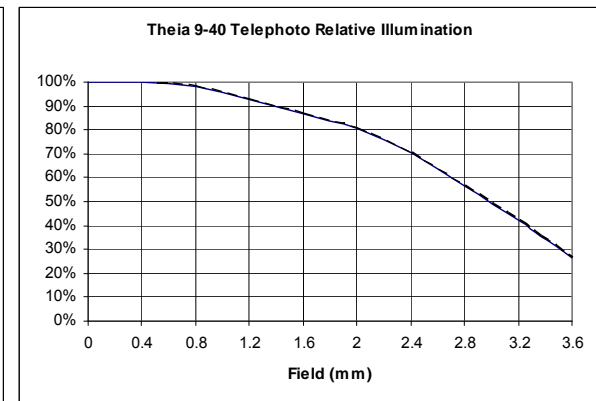

Narrow Position